



Strål
säkerhets
myndigheten

Swedish Radiation Safety Authority

Nordic Intercomparison Campaign for Whole Body Counters

NKS- Nordic Nuclear Safety Research contract AFT/B(10)6

Lilián del Risco Norrlid¹, Óskar Halldórsson², Soren Holm³, Jussi Huikari⁴,
Mats Isaksson⁵, Bjorn Lindh⁶

¹Swedish Radiation Safety Authority – SSM

²Icelandic Radiation Safety Authority – GR

³Copenhagen's University Hospital, Rigshospitalet

⁴Finnish Radiation and Nuclear Safety Authority – STUK

⁵Dep. Radiation Physics at University of Gothenburg

⁶Norwegian Radiation Protection Authority – NRPA



- ➔ Background for the project
- ➔ Nordic resources for WBC
- ➔ The web-based phantom library
- ➔ Intercomparison exercise
- ➔ Conclusions



The project aimed to :

- ➔ Inventory the resources for whole body counting in the region
- ➔ Set up an online library for calibration phantoms to establish a modern loan system in the region.
- ➔ Conduct the intercomparison exercise in order to evaluate the quality of in vivo measurements in the region
- ➔ Maintain and rebuild the good connections between facilities and specialists in order to preserve competence.



Background

- ➔ This Nordic cooperation includes: Denmark, Finland, Iceland, Norway and Sweden and involved 20 WBC facilities, stationary and field-based

- ➔ The Nordic Nuclear Safety Research- NKS (www.nks.org) sponsored the project for two consecutive years 2010 and 2011
 - NKS is a platform for Nordic cooperation and competence in nuclear safety, including radiation protection and emergency preparedness. Funds come from Nordic RP authorities (owners), companies and other organizations.

 - Transportation of the phantom used in the intercomparison for all participants
Acquisition of new radioactive material for jointly owned phantoms
Work of the country-coordinators
Phantom library website
Closing workshop



Nordic Resources for WBC

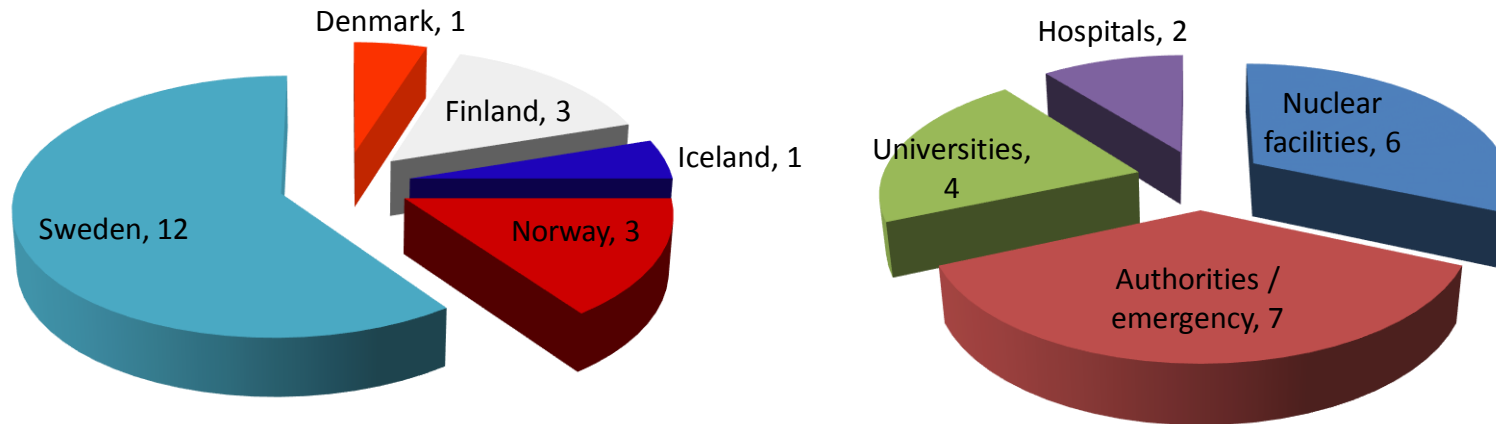

www.nks.org, NKS report 238

http://www.nks.org/en/nks_reports/



Web-based Phantom Library

- ➔ NKS has been promoting the joint acquisition of phantoms and calibration materials. In practice, an agreement regarding the “home” is reached first and the phantom is marked as jointly owned.

- ➔ Geographically, the practice of loan/ circulation of phantoms is possible thanks to the reasonable transportation time and cost.

- ➔ Loans were managed manually being the procedure time consuming and not sufficiently transparent.
 - Ex.: tracking the destination of the phantoms could become difficult when a facility borrowed directly from another facility, none of them being the “home”



Web-based Phantom Library

- Internet based approach that contains the inventory of regional phantoms. The users register to check out the available library's resources
- The library contains whole body phantoms to build in blocks of tissue equivalent material, neck phantoms and the antropomorphic phantom Livermore.
- In the stock of radioactive material there are rods for the different block-phantoms of K40, Co60, Cs137, Eu152, inserts containing Ba133+Cs137 (imitator of I131) and inserts of Eu152 for the organs of the Livermore phantom
- NKS has hosted the page for phantom library at its website:
http://www.nks.org/en/phantom_library/



Intercomparison Exercise

- ➔ The St. Petersburg whole body phantom (Irina), configuration P5, was circulated among the registered laboratories together with two sets of fully traceable radioactive material, Cs137 and K40.

- ➔ The participants were asked to report on:
 - repeatability of the measurement system with the phantom unloaded
 - whole body activities with the corresponding measurement uncertainties, for the phantom loaded with the set of rods of Cs137 and the set of rods of K40.
 - the minimum detectable activity for each radionuclide.

- ➔ Participants were given 5 working days to conduct the experiment and a week was allocated for transportation to the next laboratory.



Intercomparison Exercise

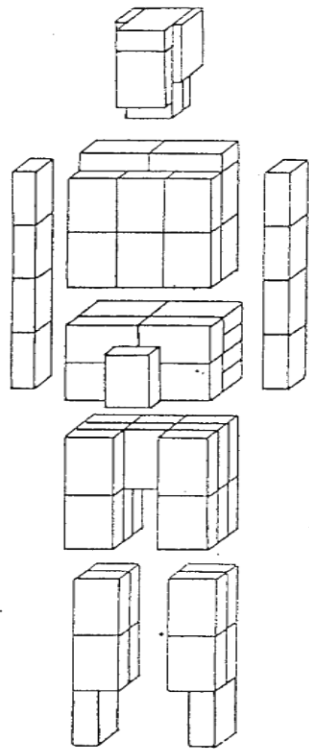

56.3kg

P4

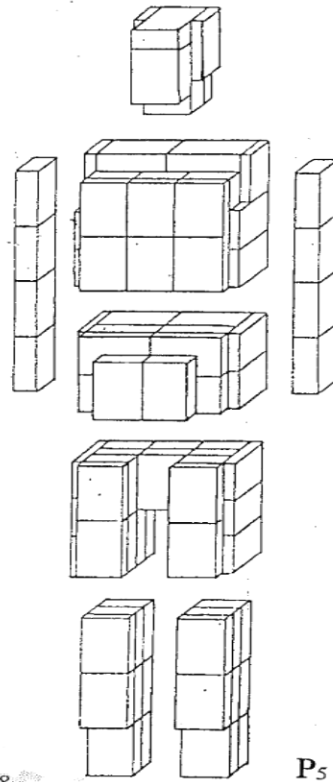

74.0kg

P5

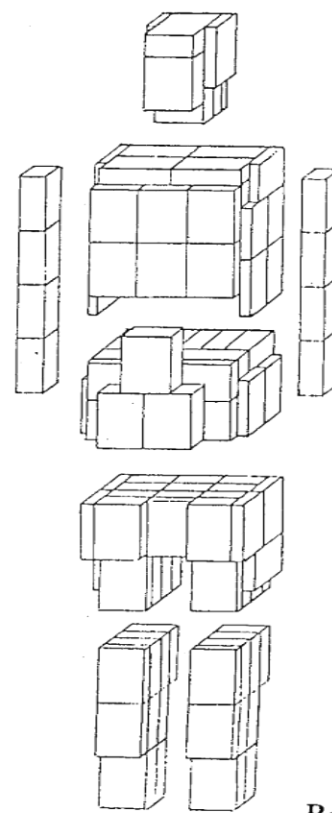

92.0kg

P6

Fig. 8.

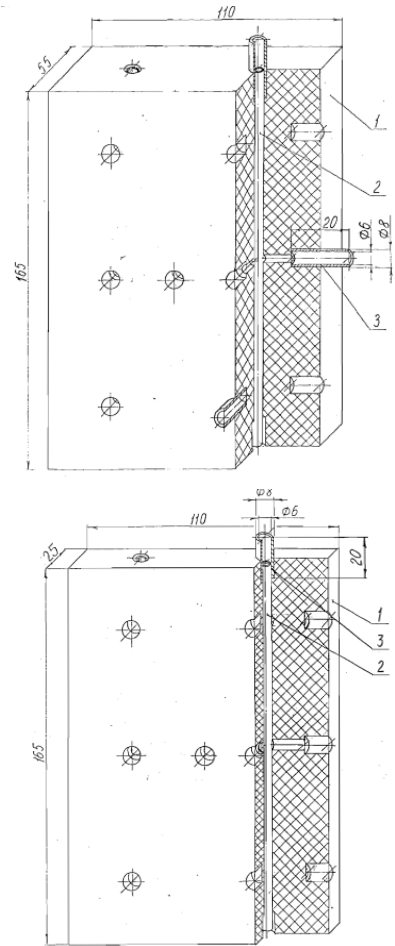



Intercomparison Exercise

- Ratio observed to Poisson precision
- z and u scores.
z-score (bias evaluation), $|z| < 2$ acceptable, $|2| < z < |3|$, questionable; $|z| > 3$, unsatisfactory
u-score (significance test), $u > 2.58 \Rightarrow$ reported value significantly differs from the target value
- The relative bias and the precision index were calculated for every reported value and compared them with pre-set values for a maximum acceptable bias (MAB) and a limit of acceptable precision (LAP).
- Combined evaluation of trueness and precision: **A** (acceptable) if both criteria for trueness and precision are met, **N** (not acceptable) in the opposite case and **W** (warning) in the case when only one of the criteria is met, given that the relative bias is below MAB.



Intercomparison Exercise

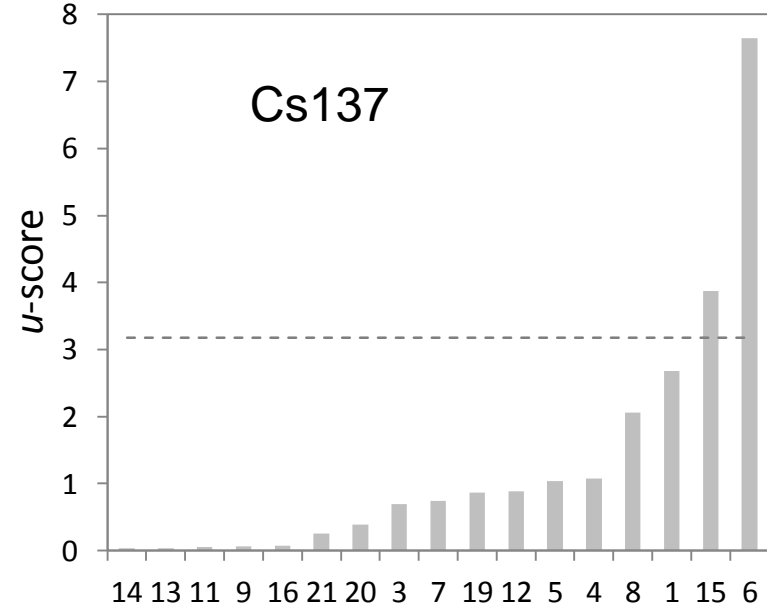
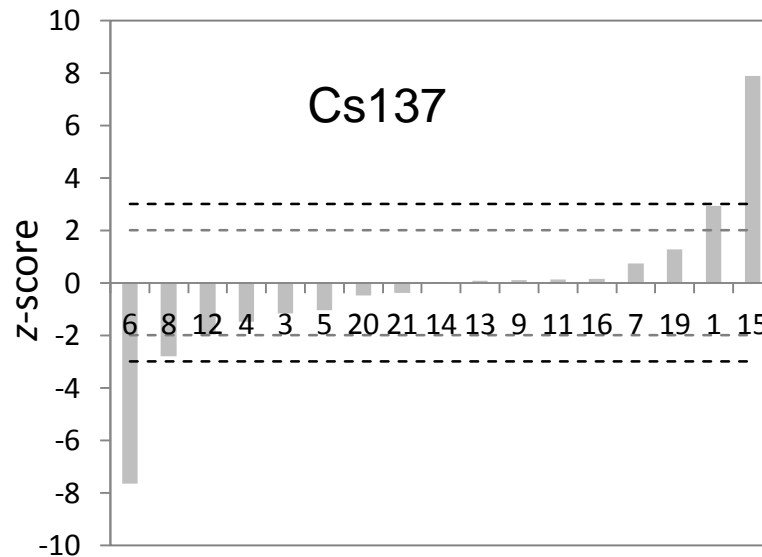
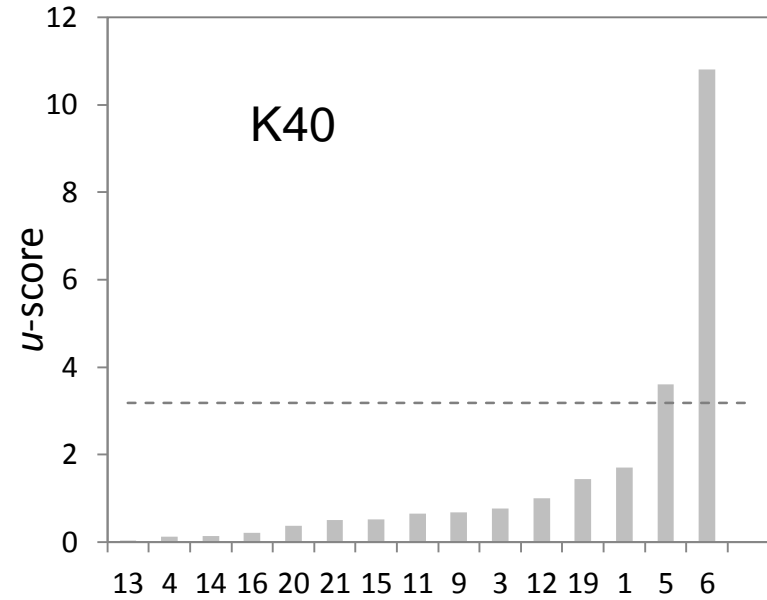
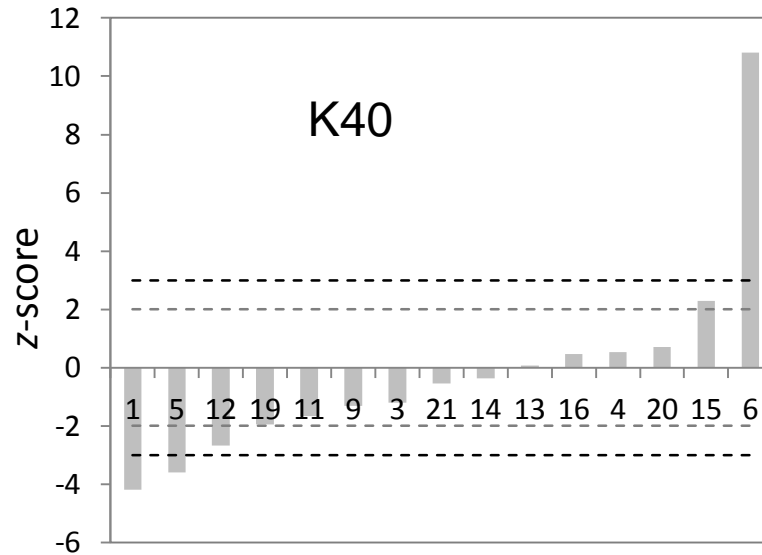

Laboratory codes

Laboratory codes



Intercomparison Exercise

K-40

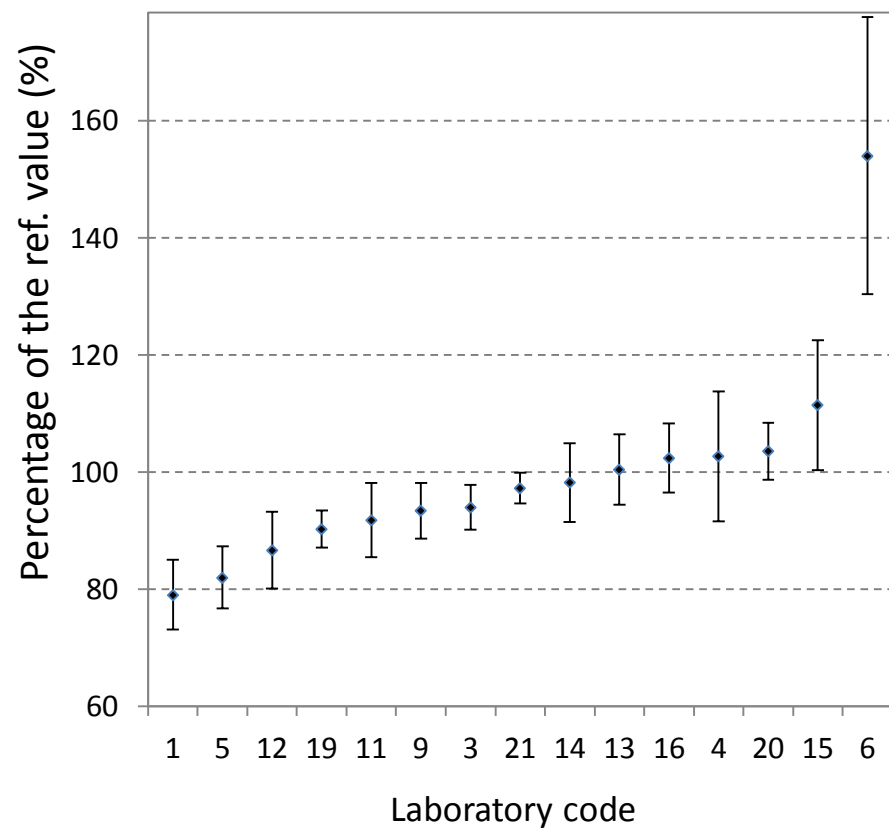

Cs-137

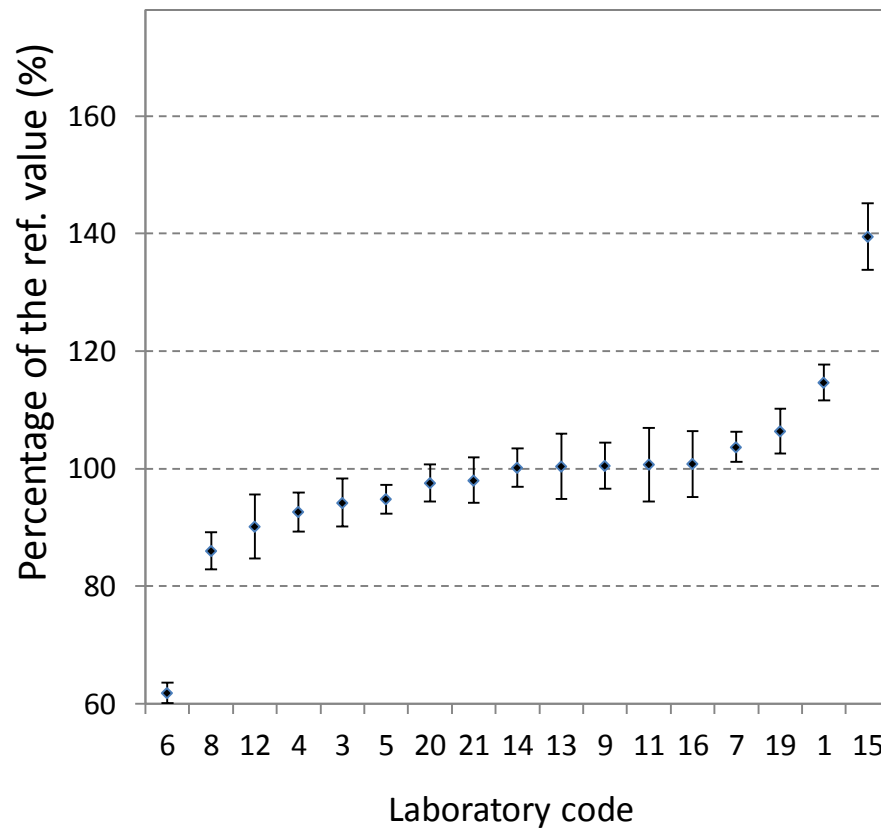



Intercomparison Exercise

Lab code	Target values		Reported values Cs137		Performance score
	Act. (Bq)	unc (Bq)	Act. (Bq)	unc (Bq)	
1	31796	1590	36452	696	A
3	31738	1587	29900	2100	A
4	31710	1586	29368	1482	A
5	24579	1229	23300	-	W
6	31558	1578	19500	-	N
7	31530	1576	32700	1000	A
8	31502	1575	27100	1450	A
9	31446	1572	31600	1900	A
11	31385	1569	31600	3600	A
12	31268	1563	28200	3100	W
13	31268	1563	31400	3100	A
14	31235	1562	31300	1300	A
15	31205	1560	43520	2770	N
16	31178	1559	31426	3143	A
19	31083	1554	33070	1700	A
20	30978	1549	30220	1200	A
21	31417	1571	30800	1900	A



Conclusions

- The project was successfully completed with an acceptable level of participation. Reports were received from 17 measurement systems out of 20 registered.
- All reporting participants determined the activity of Cs137; 15 were able to quantify the activity of both Cs137 and K40.
- Most of the participants quantified the activities of K40 and Cs137 correctly and the overall performance is equally good as the results of a previous exercise of this kind performed in 2000.
- A phantom library website has been set up. On drift since October 2011. Positive impact in the regional network of whole body counting facilities.



THANK YOU